

 **AN CAMINI**

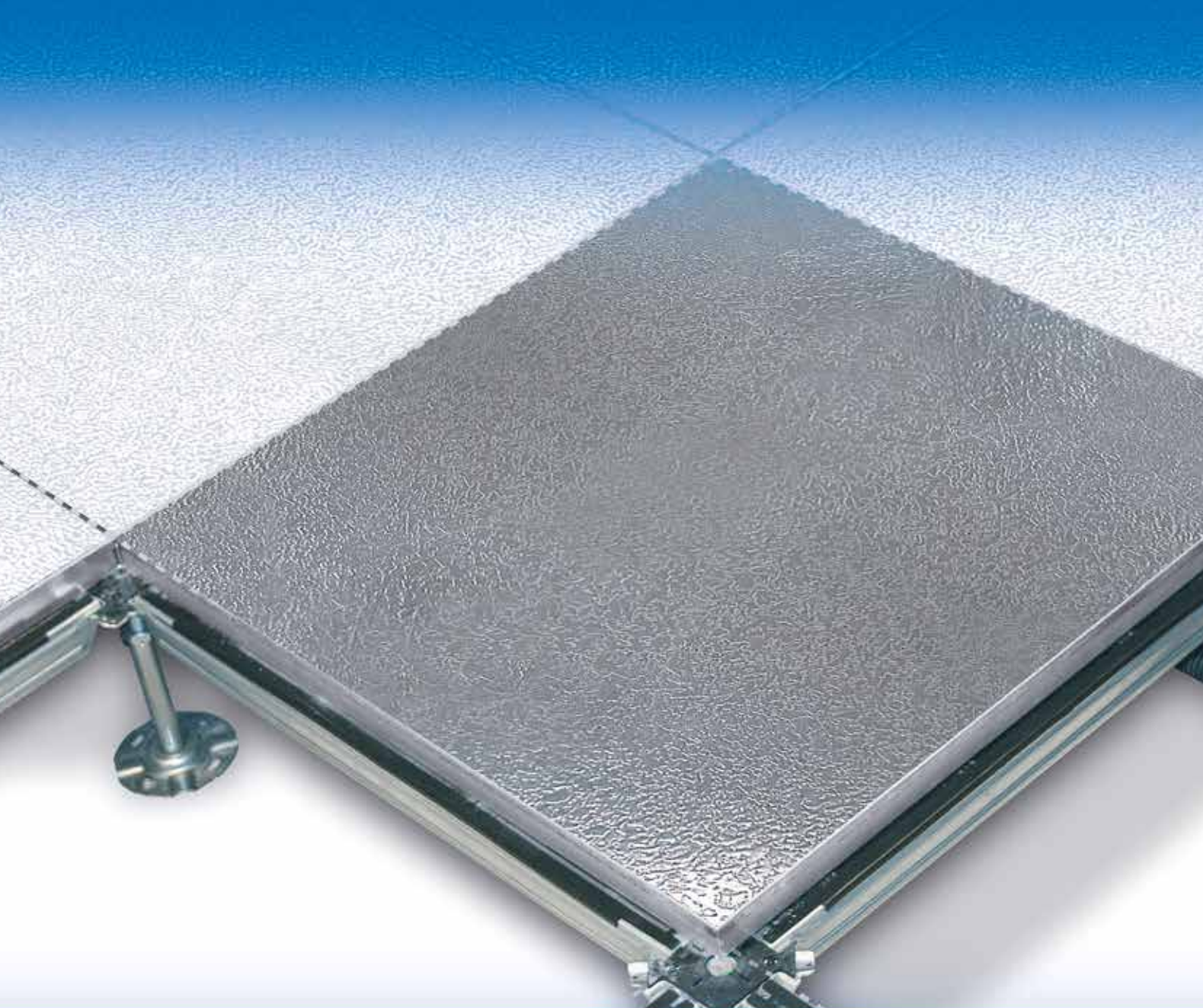

PAVIMENTO INOX
INOX FLOOR



Pavimento sopraelevato modulare mm 600 x 600, spessore mm 30, realizzato con anima centrale in truciolare ad alta densità o in solfato di calcio, nobilitati superiormente con una lamina in acciaio inox AISI 304 e inferiormente con vaschetta in acciaio zincato spessore 5/10. Struttura metallica sottostante modulare interamente in acciaio zincato, composta da piedini regolabili in altezza e traverse portanti con profilo nervato a sezione aperta, corredate di guarnizioni antirombo.

Modular floating floor 600 x 600 mm, thickness 30 mm, composed of chipboard or calcium sulphate panels with a stainless steel (AISI 304) upper surface, the support structure consists of a height-adjustable metal structure and modular connecting side pieces. Metal support structure full zinc, composed of height-adjustable supports and ribbed open section profiles, supplied with anti-noise seals.

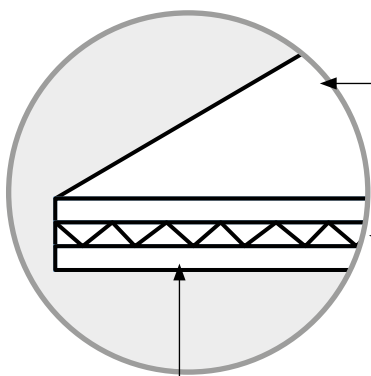
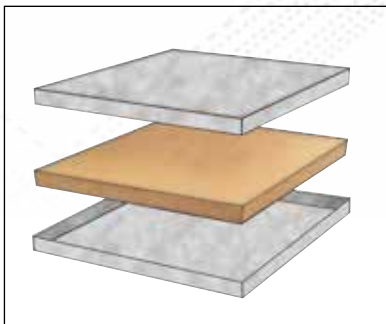
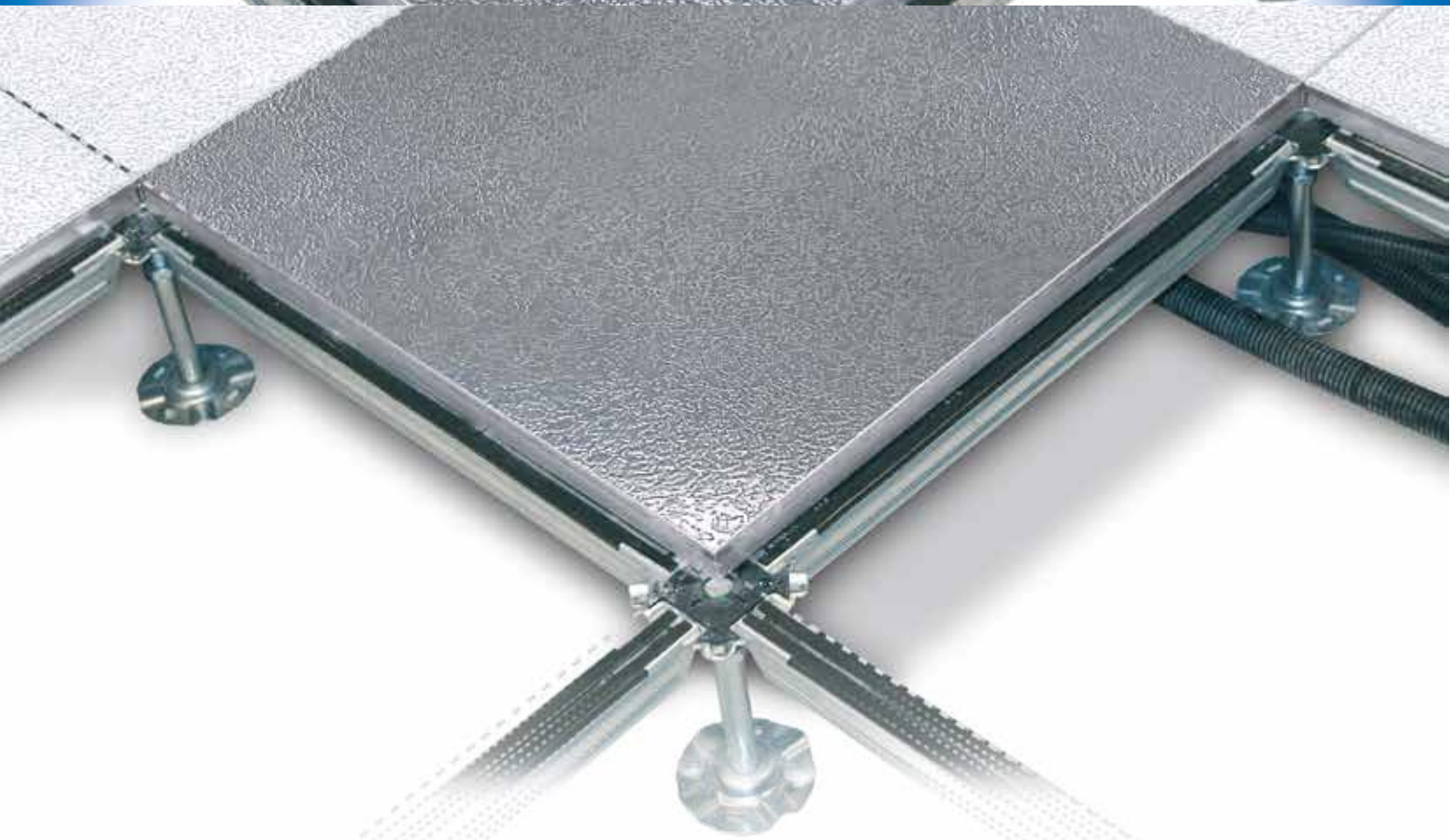

Finitura superiore: acciaio inox AISI 304
Upper finish: AISI 304

Anima del pannello:

- Truciolare ad alta densità (720 Kg +/-20 Kg)
- Solfato di calcio (1500 Kg +/-50 Kg)

Panel interior:

- High density chipboard (720 Kg +/-20 Kg)
- Calcium sulphate (1500 Kg +/-50 Kg)

Rivestimento inferiore con
vaschetta in acciaio zincato -
spessore 5/10.

Underside in galvanised steel
- thickness 5/10.

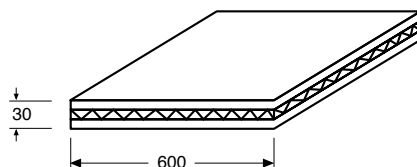

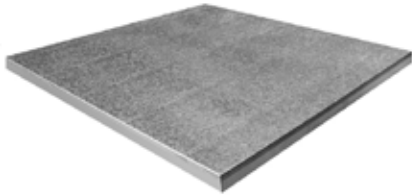

PANNELLO

Pannello 600 x 600 x 30 mm anima interna in truciolare, rivestimento in acciaio inox AISI 304.

Panel 600 x 600 x 30 mm internal core in chipboard, covering in AISI 304 stainless steel.

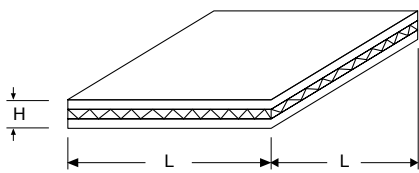

STRUTTURA PORTANTE

Struttura portante completa di guarnizioni.

Beam support structure with seals.



PIEDINO

Piedini regolabili per altezza finita a pavimento di mm 200 +/- 20 mm completi di guarnizione conduttiva.

Height-adjustable floor supports 200 mm +/- 20 mm complete with conductive seal.



COD.	L	H
PAVDEC1	600	30

COD.	Ø	H
CORRDEC1	42,4	4

COD.	Ø	L
PIEDDEC1	42,4	30



distributore - reseller

An Camini s.r.l.

24040 Zingonia di Verdellino (BG)
Via Vienna, 16
Tel. 035 051051 • Fax 035 872177
anc@ancamini.it

www.ancamini.it